



上海永明机械制造有限公司



SHANGHAI YONGMING MACHINERY MANUFACTURING CO., LTD.

Quotation of the rockwool Slitting cutting machine

The period of validity is before 2015-12-30 to this quotation.

Shanghai Yongming Machinery Manufacturing CO., LTD.

**Add: 425 Huiye road, Songjiang district Shanghai China ,
201611**

Fax:0086-21-57602104

[Tel:0086-21-57604762](tel:0086-21-57604762)

Shanghai Yongming Machinery Manufacturing Co., Ltd.(China)

Add: 425 Huiye road, Songjiang district Shanghai China, 201611

Tel: 0086-21-57604761 57604762

Fax:0086-21-57602104

Website: www.shbcm.com

E-mail: shanghaiyongming@126.com



I. rock wool slitter machine

Parameter:

- 1) Total power: about 10Kw
- 2) This machine could slit the rock wool slab which is 1200mm*1200mm (length *width), 50-100mm thickness. Its density is 100-150kg/m³.
- 3) The dimension of the machine is about 4366*1600*1575 (mm). The height of working desk is about 0.8m.
- 4) This machine could slit the rock wool slab to strip which width is 50mm, 100mm, 150mm, 200mm .
- 5) The saw knife is $\Phi 355$. The circle speed is about 1230 turn/min.
- 6) There are 4 saw cassettes (B50, B100, B150, B200) as the attachment photo showing. The worker needs to change the saw cassettes according to slitting width.
- 7) The rock wool slab will feed into the machine by roller. The speed is about 2.5m/min.
- 8) There is lift device which could press the slab and be up and down according to the thickness of rock wool slab.

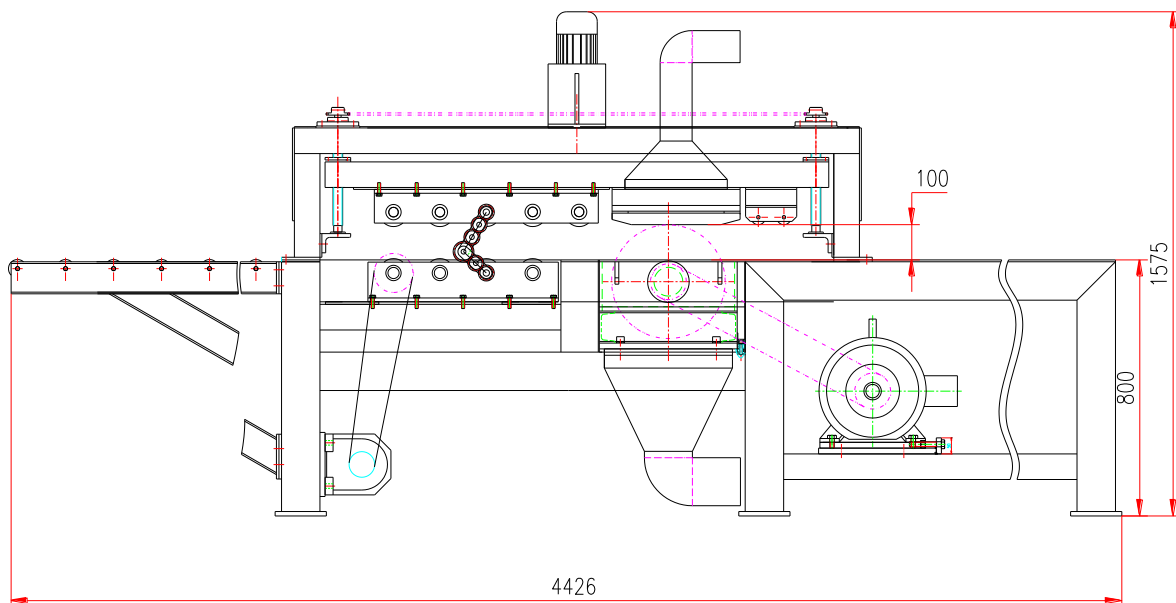

Shanghai Yongming Machinery Manufacturing Co., Ltd.(China)

Add: 425 Huiye road, Songjiang district Shanghai China, 201611

Tel: 0086-21-57604761 57604762

Fax:0086-21-57602104

Website: www.shbcm.com

E-mail: shanghaiyongming@126.com



● **TOTAL(USD,FOB SHANGHAI)**

USD 25,000

III. The transport

The machine need about 1 20' containers to transport.

IV. Workshop conditions required

- The buyer prepare the electrical source 380Volt, 50Hz.
- Workshop should be equipped with dust collecting system according to the workshop condition and local rules and regulations

V. Delivery date : 60 days after receiving the earnest.

VI. The payment

Payment terms:

30% for the earnest

70% the retentive payment shall be payoff after inspection and before handing over of the goods

VII. Warranty: 12 months limited warranty

Shanghai Yongming Machinery Manufacturing Co., Ltd.(China)

Add: 425 Huiye road, Songjiang district Shanghai China, 201611

Tel: 0086-21-57604761 57604762

Fax:0086-21-57602104

Website: www.shbcm.com

E-mail: shanghaiyongming@126.com



上海永明机械制造有限公司



SHANGHAI YONGMING MACHINERY MANUFACTURING CO., LTD.

Quotation of The rock wool trapeziform strip cutting machine

The period of validity is before 2015-12-30 to this quotation.

Shanghai Yongming Machinery Manufacturing CO., LTD.

**Add: 425 Huiye road, Songjiang district Shanghai China ,
201611**

Fax:0086-21-57604761

Tel:0086-21-57604762

Shanghai Yongming Machinery Manufacturing Co., Ltd.(China)

Add: 425 Huiye road, Songjiang district Shanghai China, 201611

Tel: 0086-21-57604761 57604762

Fax:0086-21-57602104

Website: www.shbcm.com

E-mail: shanghaiyongming@126.com



1. The rock wool trapeziform strip cutting machine

When make the roof panel , the trapeziform rockwool strip is cut on an machine and feed on the groove of sheet by manual.

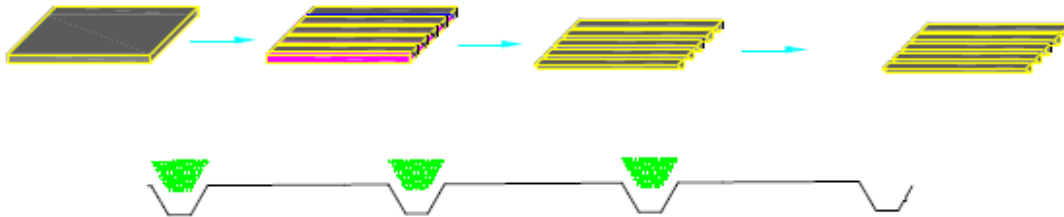

Rock wool slitter machine (Trapeziform)

Parameter:

- 1) Dimension: 4100mm*1500mm*1600mm
- 2) Total power: about 6Kw
- 3) This machine could slit the rock wool slab which is 1200mm*540mm(length *width), 32mm thickness. Its density is 100-150kg/m³.
- 4) There is only one specification of cutting on this machine. Specification could be decided according to customer's demand.
- 5) The saw knife is $\Phi 305$ - $\Phi 500$. The circle speed is about 1440 turn/min.
- 6) The rock wool slab will feed into the machine by roller. The max speed is about 4m/min, speed could be adjusted.
- 7) Processing area is closed and sealed. There is 4 dust outlets with diameter 100mm is kept on machine.

Attached drawing:

I. Sketch map of slitting

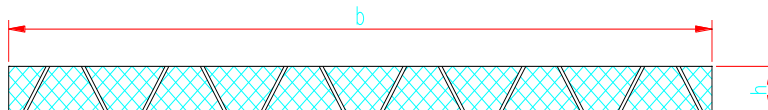

Shanghai Yongming Machinery Manufacturing Co., Ltd.(China)

Add: 425 Huiye road, Songjiang district Shanghai China, 201611

Tel: 0086-21-57604761 57604762

Fax: 0086-21-57602104

Website: www.shbcm.com

E-mail: shanghaiyongming@126.com



- The buyer prepare the electrical source 380Volt, 50Hz.
- In case of production of rock wool sandwich panel, workshop should be equipped with dust collecting system according to the workshop condition and local rules and regulations

TOTAL(USD,FOB SHANGHAI) USD 20,000

- Payment terms:
 - 30% for the down payment
 - 70% the retentive payment shall be payoff before handing over of the goods

The seller will finish manufacturing the Sandwich Panel Product Line within 60 days after receiving the earnest.

- Warranty: 12 months limited warranty

Shanghai Yongming Machinery Manufacturing CO., LTD.

Shanghai Yongming Machinery Manufacturing Co., Ltd.(China)

Add: 425 Huiye road, Songjiang district Shanghai China, 201611

Tel: 0086-21-57604761 57604762

Fax:0086-21-57602104

Website: www.shbcm.com

E-mail: shanghaiyongming@126.com