

Multi-cyclone +Post filters recovery system-for easy mobility and faster clean up operation



Multi Recovery System

- Multi-pipe type small cyclone make the contact area of powder separation more .
- Molding guide vanes make ventilation more stable uniform volume and the bottom of the powder hopper quickly removed and the side access windows make clean up easier.
- Compact structure, small size, not require so many in the space for workshop.
- You can choose to configure multiple small cyclone unit performed easily and quickly change color.

After filter system

- Multiple filters make filtering area enough.
- The efficiency of filter is up to 99%.
- The precision of filter can reach 2-5 microns.
- Advanced rotary wing filter for cleaning system.
- Automatic pulse-type counter blowing cleaning control models make the operation condition of the filter better and longer life time.
- Air package to ensure that the air flow and air pressure to clean up when you make a more thorough clean-up.
- Several side access window clean-up easier.
- Top-mounted exhaust fan with ventilation so that the form of least resistance.
- Top fan room side panel can be removed to facilitate later maintenance.

Single grade filter element powder recycle powder coating booth

- The economic and widely used powder recycle system
- Powder recycle rate it is about 98-99%
- Only suit for simple coating (2-5 colors)
- Simple and reasonable structure ,easy to maintenance

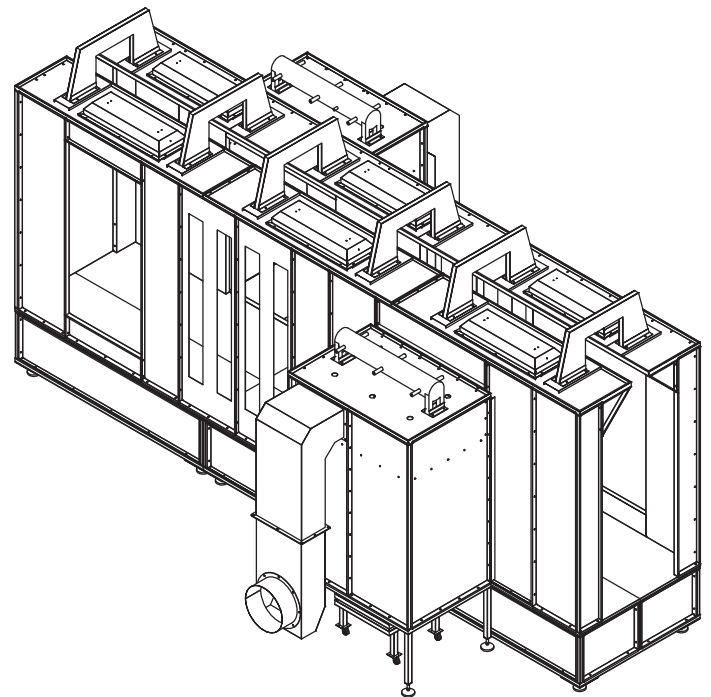
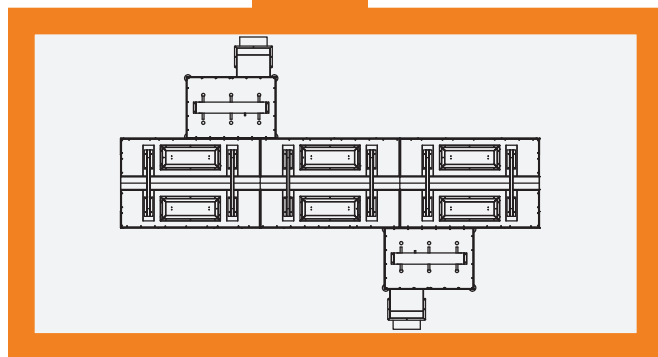
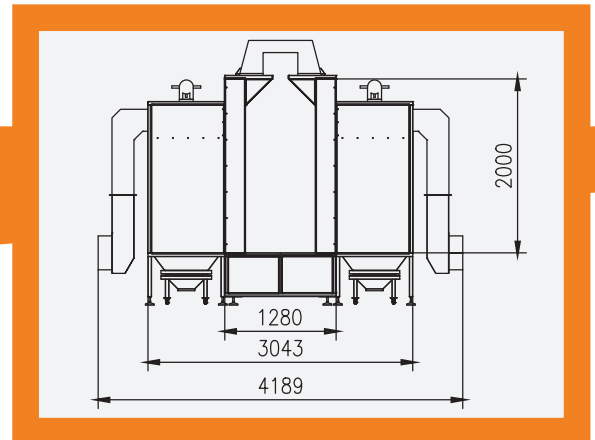
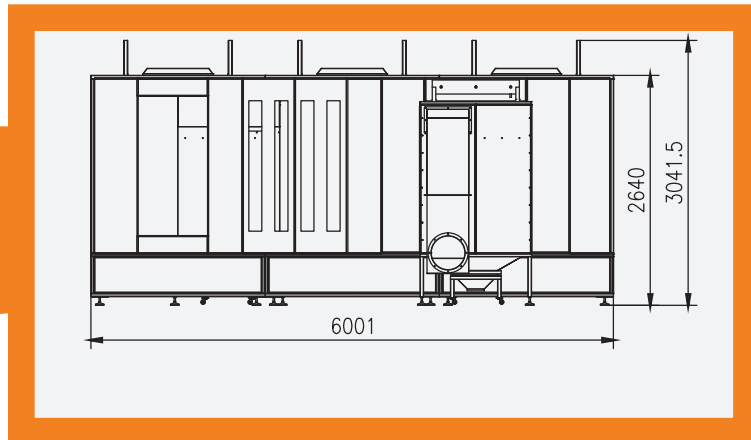

Model	COLO-S-Basic Type
Booth Type	filter type
Operator dimensions	W800*H2000*D6000mm
Overall dimensions	W1200*H2500*D7000mm
Voltage	As required

workpiece detection system

With grating induction and detection, workpiece delivers the signal which was monitored, to the central control system, then the central control system calculates the work time of workpiece's arrival towards spray gun, thus automatically opens or closes automatic spray gun, based on the conveyor chain speed that encoder has detected.

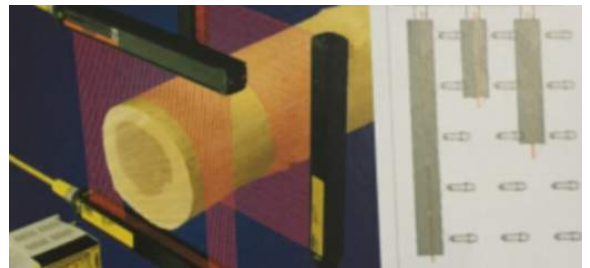

Applications:

All kinds of automatic powder coating applications.

Features:

- Automatic control;
- save powder
- reduce the empty spray;
- improve the uniformity of the layer.

Specifications:

Gap control: it opens spray gun only with the workpiece existing so as to reduce the empty spray. It is used to identify gaps and workpiece's width, which opens spray gun only with the workpiece existing. Moreover, when spraying workpieces with different width or thickness, the system can automatically adjusts the distance that the spraying gun towards the surface of workpieces to make it keep the same, in order to reduce the empty spray and improve the uniformity.

Lab spray booth



COLO-S-04548-T

(W400mm*H500mm*D480mm)

Lab curing oven



COLO-4355-T

(W450mm*H500mm*D350mm)



Colo-S-0711

(700width*1000 height *800 depth)



Colo-V-T2

Portable Voltage tester



Colo-8822

Thickness Meter



Colo-8856N

microprocessor thickness meter



Colo-0686

Gloss Meter



Rotary wing



Venturi



Titular

Polaco

Nueces



Fan motor



Powder application equipment and accessories



Spraying zozzle

Carriage filter

100% polyester ,common or imported materials can be supplied as request



Common type filter available sizes:

- 325*215*600mm
- 320*220*600mm
- 325*215*900mm
- 320*220*900mm



Powder sieve equipment

Quick-release type filter available sizes

- 325*215*600mm
- 325*215*900mm

Electric Powder Coating Curing / Drying Oven

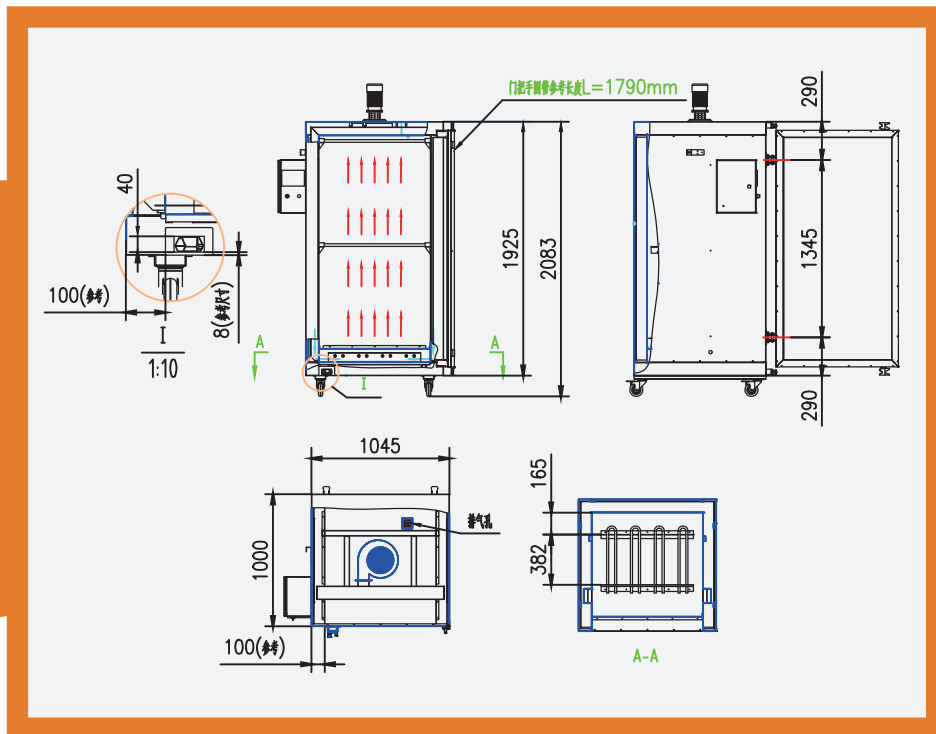

Great for wheels, composite parts, metalwork and bike frames

The colo-1688 Powder Coating Curing Oven is used in the product process of powder curing. With 2 shelves and 5 rails per shelf, there's plenty of space for hanging powder coated metal work to dry. This product will need to be hardwired or wired onto a 32AMP plug.

Product features:

- 2 shelves each with 5 removable rails
- Portable with 4 wheels included
- Voltage: 220/110V 50/60Hz
- Power: 6.5kW
- Insulation Plate: 10cm
- Warm Up Time: 25-30 minutes (180°C)
- Temperature Stability: $< \pm 1^\circ\text{C}$
- Temperature Range: 0-250°C
- Dimensions: 208.3cm H x 100cm D x 104.5cm W



COLO-1688

Electric powder coating oven



COLO-1864



COLO-1515



**Thick insulation
100-150mm**

Forced Air

Forced air circulation with booth walls and floor, curing a very good temperature uniformity result



Automatic controls-simple PLC system

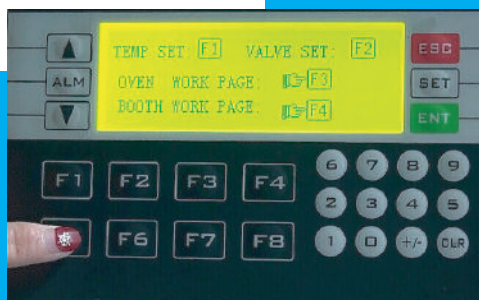

Control provides high precision heating process, it offers all the features you need. The LED display allows you to set the temperature, as well as the duration of heating process at the desired temperature.

Model	worksize dimensions (mm)	External dimensions (mm)	Fans amount	Heating power	Nominal voltage	Motor power
COLO-1688	W845 H1600 D845	W1045 H2083 D1000	1pc	7kw	As required	0.55kw
COLO-1515	W1500 H1500 D1500	W1800 H1600 D1930	1pc	12kw	As required	0.75kw
COLO-1864	W1600 H1800 D1400	W1900 H2200 D1700	1pc	12kw	As required	0.75kw
COLO-1732	W1650 H1700 D3000	W1950 H2100 D3500	1pc	18kw	As required	1.5kw
COLO-1645	W1500 H1650 D4500	W1800 H2050 D4800	1pc	32kw	As required	3kw

Powder Coating Oven With Overhead Conveyor

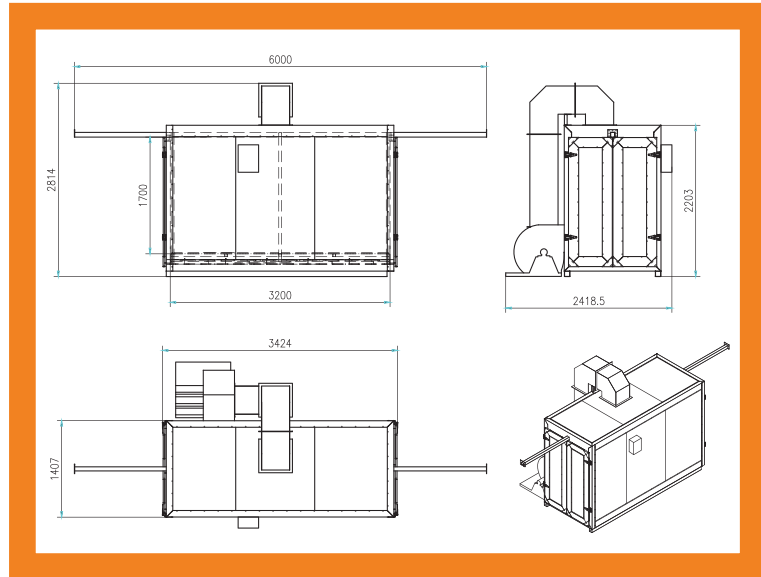

Worksize dimensions	W1200*H1700*D3200(mm)	Temperature max	250 °C
Overall dimensions	W1407*H2203*D3424(mm)	Ventilation performance	805-1677m3/h
Power supply	Electric/ 40kw	Fan motor power	2.2kw
Voltage/Frequency	As required	Circulation/ Air flow	Vertical Variable through holes on the walls
Warm-up time	15-30 min(180 °C)	Transportation	Trolley on top
Temperature stability	< ±3-5 °C	Warranty	12 months



Gas / LPG fired powder coating oven



Industrial curing batch oven.
front and back door,heat Source:LPG

**Gas or Diesel as requested
Colo-0813**

(W800mm x H1500mm x D3000mm)



- Precise temperature control, furnace tolerance of +/- 5 degrees Celsius. Indirect heating system with a heat exchanger.
- Hot air is transferred from the bottom up.
- Heat exchangers used in seamless steel tubes 8x8 array, use the combustion liner 310S stainless steel seamless pipe thickness of 3-4mm.
- Closed-round clean efficient heat circulation system.

Gas / LPG fired powder coating oven

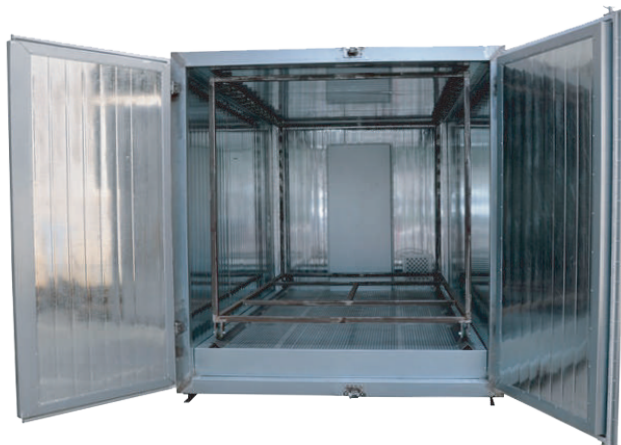

COLO-3210

Burner can be put in the side or top place
 trolley designed as request
 Exported into worldwide
 Italy imported burner



Model	Worksize dimensions W • H • D mm	Fans amount	Burner power	Heating power	Nominal voltage	motor power
Colo-0813	W800 H1500 D3000	1 pcs.	100,000cal	380V/220	380V/220	2.2kW
Colo-1732	W1700 H2200 D3000	1 pcs.	20,000cal	380V/220	380V/220	3kW
Colo-3210	W2000 H1900 D3100	1 pcs.	20,000cal	380V/220	380V/220	3KW
Colo-4772	W1606 H2060 D4797	1 pcs	30,000 cal	380V/220	380V/220	5.5KW

Infrared Catalytic Gas Burner



Electric pulse igniter



Solenoid Valve



Ignition pin



Infrared Catalytic Ceramic Plate

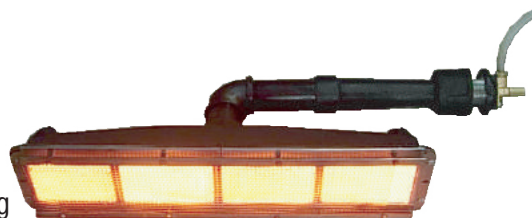

Working

Specification

Model	Dimension mm	N.W. kg	Gas Type	Heat Output		Consumption	
				KW/h	Kcal/hr	NG(m3/h)	LPG(kg/h)
HD162	570*130*175	8	NG/LPG	6.3	5400	0.49	0.45
HD242	840*130*175	11.7	NG/LPG	9.4	8120	0.75	0.68
HD262	930*130*175	13	NG/LPG	10.9	9360	0.8	0.74

Note :When you order please advise the source type and working voltage details

COLO-SMT-7

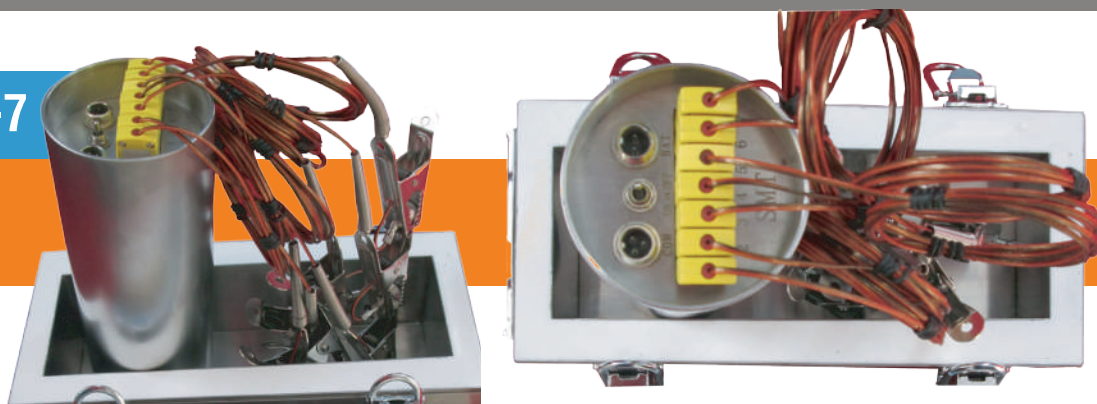

Channel Number	7 Channel				
Temperature	0~500C	Thermocouple	K	Memory	128 K
Resolution	0.5c				
Use Time	600min under 100C ,or 120min under 200C or 60min under 300C				
Recorder Time	4h under sample rate 1s				
Sample Rate	1s, 2s, 3s, 5s, 8s, 10s, 12s, 20s,40s, 60s				
Thermal Barrier	280(length) x 120(width) x 100(height)				
Setting Software (TrendReader V1.22)	<ol style="list-style-type: none"> 1) To select or unselect each channel with Yes or NO 2) To verify the accuracy separately for each channel 3) Easy to choose sample rate 4) Switch ON/OFF 				
Analysis Software (TrendReporter V1.0)	<ol style="list-style-type: none"> 1) To display temperature data 2) To calculate heating rate between two temperature level 3) To calculate total time above two different temperature 4) To Calculate Peak Temperature 5) To Compare different temperature profile 6) To Print Report 				



COLO-SMT-4

Channel Number	4 Channel
thermocouple	K
Use time	60min under 300C .
Thermal Barrier	325(length) x 125(width) x 125(height)
Memory	per channel can record and store 16 000 data
Sample Rate	1s, 2s, 3s, 4s, 5s, 6s, 10s, 20s, 30s, 1min, etc., can be selected by the user
Computer request	windows 98, 2000, XP ect ,through the computer to print out temperature curve
Setting Software	<ol style="list-style-type: none"> a) sampling period Optional b) start / stop recording easy
Analysis Software	<ol style="list-style-type: none"> a) The curve optional display or not display b) can be calculated at any temperature between the two heating rate; c) be able to calculate the temperature higher than a four time; d) can be calculated peak temperature; e) be able to compare test data 2-5 times
Standard configuration	<ul style="list-style-type: none"> * Four-channel Temperature Tracker * 4pcs of 1.75 meters temperature probe * Computer connection cable * Data processing software, data analysis software * Stainless steel incubator, including suspension handle * Operating Manual

